

Safety warning lights | § 53 a Abs. 1 StVZO

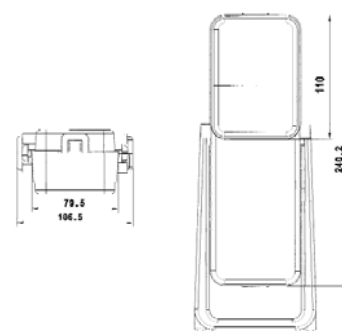

Art.-No.	Description
	Halogen safety warning light <ul style="list-style-type: none"> · Type P31 with steady light · Version with rechargeable battery · Equipment: 5 x mono cells LR 20 · With chargeable cable, universal 12 / 24 V · Overcharging and deep discharge protection · GGVS controlled
750 000 000	Bulk (without mono cells)
750 000 001	Individual cardboard box (without mono cells)
750 000 002	Hard box (without mono cells)



Art.-No.	Description
	Halogen safety warning light <ul style="list-style-type: none"> · Type P32 without steady light · Version with mono cells · Equipment: 5 x mono cells LR 20 · GGVS controlled
765 000 000	Bulk (without mono cells)
765 000 001	Individual cardboard box (without mono cells)
765 000 002	Hard box (without mono cells)



Accessories	
750 000 300	Hard box

