

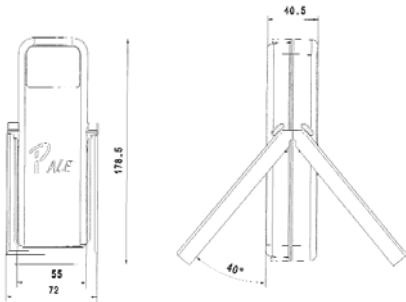

Safety warning lights | § 53 a Abs. 1 StVZO

LED



Art.-No.	Description
	LED-Safety warning light PALE <ul style="list-style-type: none"> Equipment: 2x mono cells LR 20 GGVS controlled Blinking light > 150 hours, steady light > 5 hours The electronics used (Boost-Converter) ensure uniform brightness over the entire service life and optimum utilization of the battery capacity
767 000 000	Bulk (without mono cells)
767 000 001	Cardboard box (without mono cells)



Art.-No.	Description
	Halogen safety warning light <ul style="list-style-type: none"> Type 30 with steady light Battery version Equipment: 5x mono cells LR 20 GGVS controlled
760 000 000	Bulk (without mono cells)
760 000 001	Cardboard box (without mono cells)
760 000 002	Hard box (without mono cells)

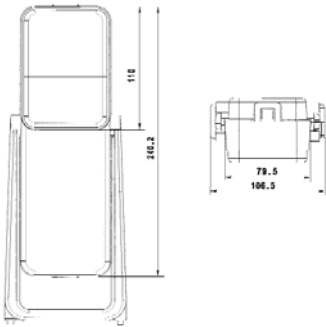

Accessories	
750 000 300	Hard box